

仕様書

形名
CDR74

1. 外形

1-1. 寸法図(mm)

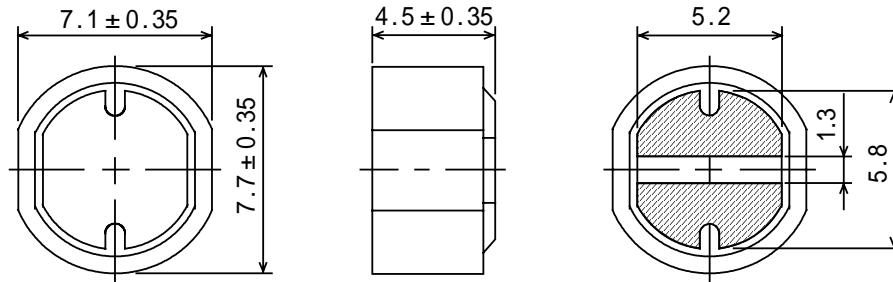

* 公差のない寸法は参考値とする。

1-2. 捺印表示例

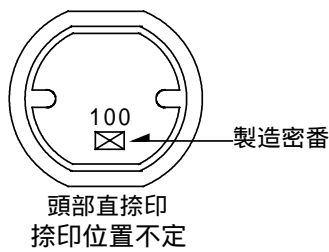

1-3. 推奨ランド図 (mm)

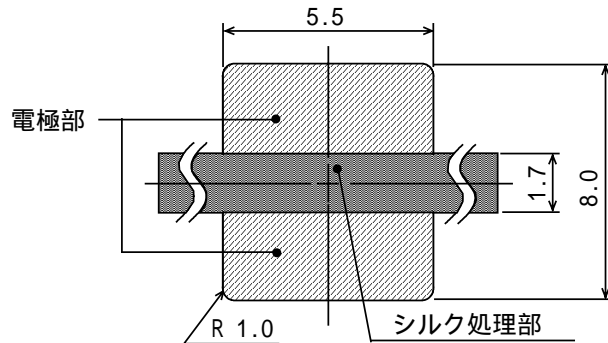

電極（端子）間の隙間はシルク処理をして御使用下さい。

2. コイル仕様

2-1. 端子接続図(裏面図)

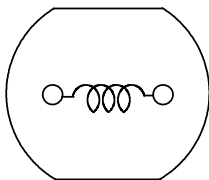

RoHS

compliance
Cd: Max. 0.01wt%
others: Max. 0.1wt%

仕様書

形名 CDR74

2-2. 電気的特性 (リール梱包の場合)

NO.	品名	表示	インダクタンス [以内] 1	D.C.R. () [以下] (at 20)	定格電流 (A) 2	S.R.F. (MHz) [参考値]	スミダ コード
01	CDR74NP-100NC	100	+25% 10 μH - 15%	0.07	1.64	29.8	-0066
02	CDR74NP-120NC	120	+25% 12 μH - 15%	0.08	1.50	26.4	-0067
03	CDR74NP-150NC	150	+25% 15 μH - 15%	0.09	1.34	21.1	-0068
04	CDR74NP-180NC	180	+25% 18 μH - 15%	0.11	1.22	20.0	-0069
05	CDR74NP-220NC	220	+25% 22 μH - 15%	0.12	1.10	19.5	-0070
06	CDR74NP-270NC	270	+25% 27 μH - 15%	0.17	1.00	16.5	-0071
07	CDR74NP-330NC	330	+25% 33 μH - 15%	0.19	0.90	15.5	-0072
08	CDR74NP-390NC	390	+25% 39 μH - 15%	0.21	0.83	14.4	-0073
09	CDR74NP-470NC	470	+25% 47 μH - 15%	0.24	0.75	12.8	-0074
10	CDR74NP-560NC	560	+25% 56 μH - 15%	0.32	0.69	11.6	-0075
11	CDR74NP-680NC	680	+25% 68 μH - 15%	0.37	0.63	10.2	-0077
12	CDR74NP-820NC	820	+25% 82 μH - 15%	0.40	0.57	9.95	-0078
13	CDR74NP-101MC	101	+20% 100 μH - 15%	0.54	0.52	8.59	-0079
14	CDR74NP-121MC	121	+20% 120 μH - 15%	0.62	0.47	7.53	-0080
15	CDR74NP-151MC	151	+20% 150 μH - 15%	0.86	0.42	7.00	-0081
16	CDR74NP-181MC	181	+20% 180 μH - 15%	0.97	0.38	6.53	-0082
17	CDR74NP-221MC	221	+20% 220 μH - 15%	1.31	0.35	5.07	-0083
18	CDR74NP-271MC	271	+20% 270 μH - 15%	1.46	0.31	4.67	-0084

仕様書

形名 CDR74

2-3. 電気的特性 (箱梱包の場合)

NO.	品名	表示	インダクタンス [以内] 1	D.C.R. () [以下] (at 20)	定格電流 (A) 2	S.R.F. (MHz) [参考値]	スミダ コード
19	CDR74NP-100NB	100	+25% 10 μ H - 15%	0.07	1.64	29.8	-0085
20	CDR74NP-120NB	120	+25% 12 μ H - 15%	0.08	1.50	26.4	-0086
21	CDR74NP-150NB	150	+25% 15 μ H - 15%	0.09	1.34	21.1	-0088
22	CDR74NP-180NB	180	+25% 18 μ H - 15%	0.11	1.22	20.0	-0089
23	CDR74NP-220NB	220	+25% 22 μ H - 15%	0.12	1.10	19.5	-0090
24	CDR74NP-270NB	270	+25% 27 μ H - 15%	0.17	1.00	16.5	-0091
25	CDR74NP-330NB	330	+25% 33 μ H - 15%	0.19	0.90	15.5	-0092
26	CDR74NP-390NB	390	+25% 39 μ H - 15%	0.21	0.83	14.4	-0093
27	CDR74NP-470NB	470	+25% 47 μ H - 15%	0.24	0.75	12.8	-0094
28	CDR74NP-560NB	560	+25% 56 μ H - 15%	0.32	0.69	11.6	-0095
29	CDR74NP-680NB	680	+25% 68 μ H - 15%	0.37	0.63	10.2	-0096
30	CDR74NP-820NB	820	+25% 82 μ H - 15%	0.40	0.57	9.95	-0097
31	CDR74NP-101MB	101	+20% 100 μ H - 15%	0.54	0.52	8.59	-0099
32	CDR74NP-121MB	121	+20% 120 μ H - 15%	0.62	0.47	7.53	-0100
33	CDR74NP-151MB	151	+20% 150 μ H - 15%	0.86	0.42	7.00	-0101
34	CDR74NP-181MB	181	+20% 180 μ H - 15%	0.97	0.38	6.53	-0102
35	CDR74NP-221MB	221	+20% 220 μ H - 15%	1.31	0.35	5.07	-0103
36	CDR74NP-271MB	271	+20% 270 μ H - 15%	1.46	0.31	4.67	-0104

1: 測定周波数 L 10 μ H ~ 82 μ H ; at 2.52 MHz
 100 μ H ~ 270 μ H ; at 1 kHz

2: 定格電流は直流重畳特性に於て、インダクタンスが公称値より-20%となる電流、もしくは直流電流を流した時のコイルの発熱が t = 40 となる電流値の少ない方の値。(Ta=20 を基準とする。)

3. 保存温度範囲 - 40 ~ + 85
 使用温度範囲 - 40 ~ + 85 (コイルの発熱を含む。)

SPECIFICATION

TYPE CDR74

1 . APPEARANCE

1-1 . DIMENSIONS(mm)

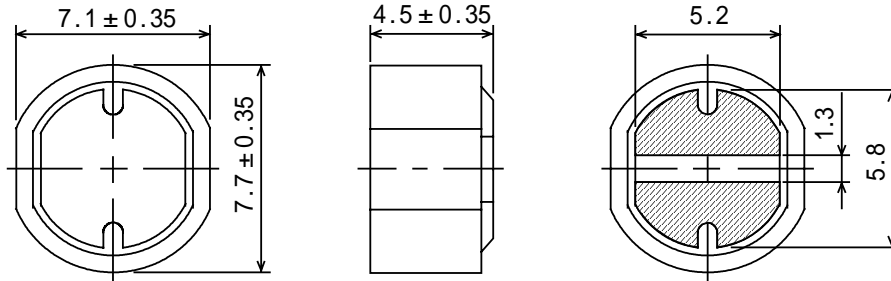

* DIMENSIONS WITHOUT TOLERANCE ARE APPROX.

1-2 . STAMP (E.G.)

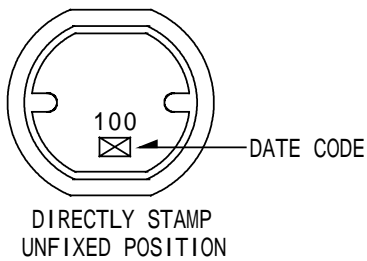

1-3.RECOMMENDED LAND PATTERNS DIMENSION (mm)

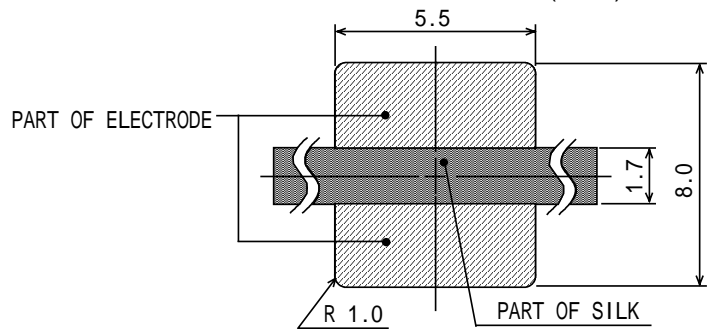

PLEASE COAT WITH SILK SCREEN BETWEEN THE TWO ELECTRODES.

2 . COIL SPECIFICATION

2-1 . CONNECTION (BOTTOM VIEW)

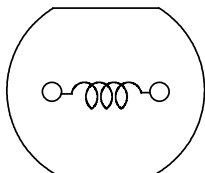

RoHS compliance Cd:Max.0.01wt% others:Max.0.1wt%
--

SPECIFICATION

TYPE CDR74

2-2 . ELECTRICAL CHARACTERISTICS (IN THE CASE OF REEL)

NO.	PART NO.	STAMP	INDUCTANCE [WITHIN] 1	D.C.R. () [MAX.] (at 20)	RATED CURRENT (A) 2	S.R.F. (MHz) [TYP.]	SUMIDA CODE
01	CDR74NP-100NC	100	+ 25% 10 μH - 15%	0.07	1.64	29.8	-0066
02	CDR74NP-120NC	120	+ 25% 12 μH - 15%	0.08	1.50	26.4	-0067
03	CDR74NP-150NC	150	+ 25% 15 μH - 15%	0.09	1.34	21.1	-0068
04	CDR74NP-180NC	180	+ 25% 18 μH - 15%	0.11	1.22	20.0	-0069
05	CDR74NP-220NC	220	+ 25% 22 μH - 15%	0.12	1.10	19.5	-0070
06	CDR74NP-270NC	270	+ 25% 27 μH - 15%	0.17	1.00	16.5	-0071
07	CDR74NP-330NC	330	+ 25% 33 μH - 15%	0.19	0.90	15.5	-0072
08	CDR74NP-390NC	390	+ 25% 39 μH - 15%	0.21	0.83	14.4	-0073
09	CDR74NP-470NC	470	+ 25% 47 μH - 15%	0.24	0.75	12.8	-0074
10	CDR74NP-560NC	560	+ 25% 56 μH - 15%	0.32	0.69	11.6	-0075
11	CDR74NP-680NC	680	+ 25% 68 μH - 15%	0.37	0.63	10.2	-0077
12	CDR74NP-820NC	820	+ 25% 82 μH - 15%	0.40	0.57	9.95	-0078
13	CDR74NP-101MC	101	+ 20% 100 μH - 15%	0.54	0.52	8.59	-0079
14	CDR74NP-121MC	121	+ 20% 120 μH - 15%	0.62	0.47	7.53	-0080
15	CDR74NP-151MC	151	+ 20% 150 μH - 15%	0.86	0.42	7.00	-0081
16	CDR74NP-181MC	181	+ 20% 180 μH - 15%	0.97	0.38	6.53	-0082
17	CDR74NP-221MC	221	+ 20% 220 μH - 15%	1.31	0.35	5.07	-0083
18	CDR74NP-271MC	271	+ 20% 270 μH - 15%	1.46	0.31	4.67	-0084

SPECIFICATION

TYPE CDR74

2-3.ELECTRICAL CHARACTERISTICS (IN THE CASE OF BOX)

NO.	PART NO.	STAMP	INDUCTANCE [WITHIN] 1	D.C.R. () [MAX.] (at 20)	RATED CURRENT (A) 2	S.R.F. (MHz) [TYP.]	SUMIDA CODE
19	CDR74NP-100NB	100	+25% 10 μH - 15%	0.07	1.64	29.8	-0085
20	CDR74NP-120NB	120	+25% 12 μH - 15%	0.08	1.50	26.4	-0086
21	CDR74NP-150NB	150	+25% 15 μH - 15%	0.09	1.34	21.1	-0088
22	CDR74NP-180NB	180	+25% 18 μH - 15%	0.11	1.22	20.0	-0089
23	CDR74NP-220NB	220	+25% 22 μH - 15%	0.12	1.10	19.5	-0090
24	CDR74NP-270NB	270	+25% 27 μH - 15%	0.17	1.00	16.5	-0091
25	CDR74NP-330NB	330	+25% 33 μH - 15%	0.19	0.90	15.5	-0092
26	CDR74NP-390NB	390	+25% 39 μH - 15%	0.21	0.83	14.4	-0093
27	CDR74NP-470NB	470	+25% 47 μH - 15%	0.24	0.75	12.8	-0094
28	CDR74NP-560NB	560	+25% 56 μH - 15%	0.32	0.69	11.6	-0095
29	CDR74NP-680NB	680	+25% 68 μH - 15%	0.37	0.63	10.2	-0096
30	CDR74NP-820NB	820	+25% 82 μH - 15%	0.40	0.57	9.95	-0097
31	CDR74NP-101MB	101	+20% 100 μH - 15%	0.54	0.52	8.59	-0099
32	CDR74NP-121MB	121	+20% 120 μH - 15%	0.62	0.47	7.53	-0100
33	CDR74NP-151MB	151	+20% 150 μH - 15%	0.86	0.42	7.00	-0101
34	CDR74NP-181MB	181	+20% 180 μH - 15%	0.97	0.38	6.53	-0102
35	CDR74NP-221MB	221	+20% 220 μH - 15%	1.31	0.35	5.07	-0103
36	CDR74NP-271MB	271	+20% 270 μH - 15%	1.46	0.31	4.67	-0104

1: MEASURED FREQUENCY L 10 μH ~ 82 μH ; at 2.52 MHz
100 μH ~ 270 μH ; at 1 kHz

2: THIS INDICATES THE VALUE OF CURRENT WHEN THE INDUCTANCE IS 20% LOWER THAN ITS NOMINAL VALUE
AT D.C. SUPERPOSITION OR D.C. CURRENT WHEN T=40 WHICH EVER IS LOWER. (Ta=20)

3 . STORAGE TEMPERATURE RANGE : - 40 ~ + 85
OPERATING TEMPERATURE RANGE: - 40 ~ + 85 (INCLUDING COIL'S SELF TEMPERATURE RISE)